

Small Size – Engineered Plastics

LS-3 Series – Offers High Reliability, Compact Size and Low Costs in NPT, Straight and Metric Threads

Ideal for shallow tanks or restricted spaces, or for any low-cost, high volume use. LS-3 Series are available in FDA approved materials, consult GEMS for details.

Polysulfone Float



For water based liquids, with limited use in oils and chemicals.

Polypropylene Float (Hollow)



Features a low specific gravity float offering broad chemical compatibility to satisfy a wide variety of applications.

Polypropylene Float (Solid)



With Polypropylene stem and float, switch offers broad chemical compatibility.

Buna N Float



Ideal for oils and fuels.

Dimensions

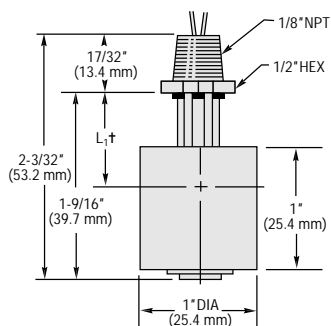

† L₁ = Switch actuation level, nominal (based on a liquid specific gravity of 1.0).

Polysulfone Float:
3/4" (19.0 mm)

Polypropylene Float (Hollow):
13/16" (20.6 mm)

Polypropylene Float (Solid):
9/16" (14.3 mm)

Buna N Float:
13/16" (20.6 mm)

Alternate Mountings

	3/8"-16 Straight Thread	G1/8" 1/8"-28 BSP	M12x 1.5 Straight Thread
Electrical Termination	Lead Wires	Cable	Cable

Common Specifications

Electrical Termination: No. 22 AWG, 24" L., PVC Lead Wires. On BSP and Metric mounting: PVC Jacketed 2-Conductor #22AWG Cable.

Approvals: U.L. Recognized – File No. E45168; CSA Listed – File No. 30200. CE Declaration Available Upon Request.

Switch SPST: 20 VA, 120-240 VAC. Units are shipped N.O. unless otherwise specified.

Selectable, N.O. or N.C., by inverting float on unit stem.

How To Order – Select Part Number based on specifications required.

Materials						
Stem and Mounting	Float	Min. Liquid Sp. Gr.	Pressure** PSI/Bar, Max.	Operating Temperature	Mounting Type	Part Number
Polysulfone	Polysulfone	.75	50/3	-40°F to +225°F (-40°C to +107°C)	1/8" NPT	42295 ⚡
Polypropylene	Polypropylene (Hollow)	.60	50/3	-40°F to +225°F (-40°C to +107°C)	1/8" NPT	142505 ⚡
				-40°F to +176°F (-40°C to +80°C)	3/8"-16	171517
	Polypropylene (Solid)	.90	150/10	-40°F to +150°F (-40°C to +66°C)	G 1/8"-24	171518
				-40°F to +176°F (-40°C to +80°C)	M12x1.5	171519
Nylon	Buna	.45	150/10	-40°F to +250°F (OIL) (-40°C to +121°C [OIL])	1/8" NPT	116826 ⚡
				-40°F to +176°F (-40°C to +80°C)	3/8"-16	171514
				-40°F to +176°F (-40°C to +80°C)	G 1/8"-24	171515
					M12x1.5	171516
					1/8" NPT	162745 ⚡
					3/8"-16	171511
					G 1/8"-24	171512
					M12x1.5	171513

**Maximum Pressure at 70°F (30°C)
⚡ – Stock Items.

Accessories Available in OEM Quantities:
Jam Nut, Gaskets, and Sloss Shields.

Unique Features Make These LS-3 Models Special

These small switches feature unique configurations for special applications.

Part No. 142545
With Slosh Shield



Cut-away version shown

Compact, all-polypropylene switch with slosh shield is ideal for use with turbulent liquids in small tanks. FDA approved materials.

Part No. 46999
Bottle Level



For external mounting on tanks too small to accommodate internally mounted switches. (See note below)

Part No. 76707
For Low Level



For detecting levels as low as 5/8" from tank bottom. Use in water, gasoline, some oils and chemicals.

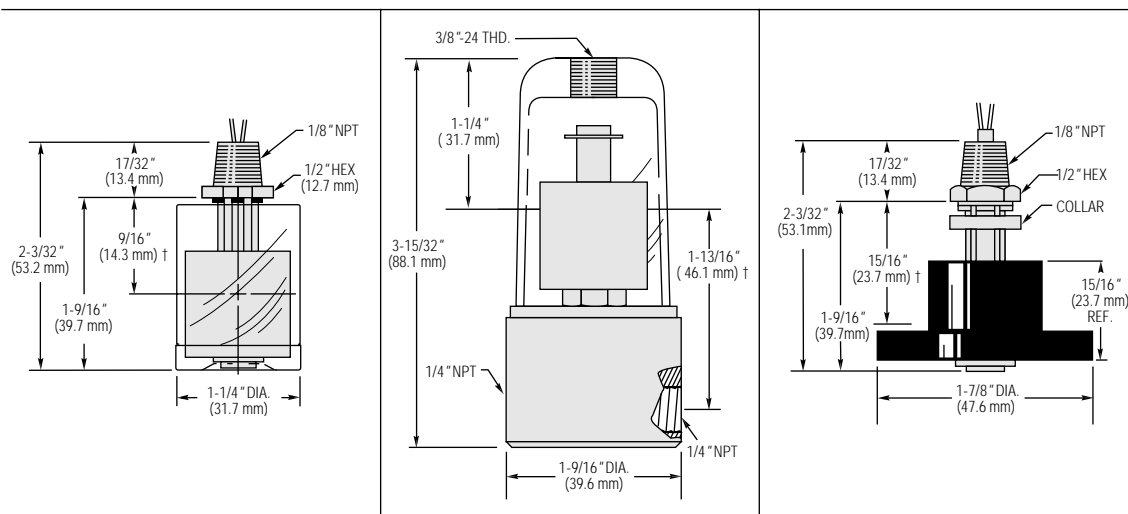

Order By Part Number	142545 ⚡	46999 ⚡	76707 ⚡
Materials			
Stem and Mounting	All Polypropylene (Including Shield††)	Polysulfone	All Polysulfone (Including Collar)
Float	Polypropylene (Solid)	Polysulfone	Buna N
Other Wetted	—	Brass, Aluminum, Polycarbonate, Viton A	Epoxy
Min. Liquid Sp. Gr.	.90	.75	—
Operating Temperature	-40°F to +150°F (-40°C to +65.6°C)	-40°F to +120°F (-40°C to +48.9°C)	-40°F to +180°F (-40°C to +82.2°C)
Pressure, PSI, Max. ***	150	50	
Switch*, SPST	20 VA, N.C./N.O./Dry**	20 VA, N.C. Dry	
Electrical Termination	No. 22 AWG, 22" L., PVC Lead Wires	No. 22 AWG, 72" L.; Polymeric Lead Wires	No. 22 AWG, 72" L., PVC Lead Wires

* See "Electrical Data" on Page A-4 for more information.

** Switch operation is selectable, N.O. or N.C., by inverting the float on the unit stem.

*** Maximum pressure at 70°F (30°C).

† L₁ = Switch actuation level, nominal (based on a specific gravity of 1.0).

†† Consult factory for other available materials.

⚡ - Stock Items.

Note: LS-3 Series Bottle Level Switch is also available with any of the float materials shown on opposite page. Contact GEMS for correct part number.