



# Externally-Mounted Bottle-Style Level Switches

## LS-800 Type 5

Instruction Bulletin No. 78799

### To Install . . .

Locate and prepare entrances in tank side so that level switch unit will be in vertical position with wire leads up when installed on outside of tank. Connect NPT inlet and outlet ports of unit to tank entrances. 1/2" NPT in top of unit provides for electrical connection. **(See wiring information below and on back of sheet.)** Use 1/4"-20 threaded mounting holes or optional mounting bracket (Kit P/N 167809) to attach unit on any suitable vertical surface.

### - Multi-Level Units -

#### Specifications

<b>Housing Material</b>	Brass	316 Stainless Steel
<b>Stem and Mounting</b>	Brass	316 Stainless Steel
<b>Port Sizes</b>	3/4" NPT	
<b>Max. Length (L<sub>0</sub>)</b>	140" (355.6 cm)	
<b>Float Stops**</b>	Beryllium Copper	S.S. ARMCO PH-15-7 MO
<b>Switch</b>	20 VA (Pilot Duty)	

\*\* Units greater than 72" overall length are supplied with collars with setscrews (made of same material as stem and mounting) in place of float-stop rings. Collars are optional on units less than 72" overall length. Units requiring 316 SS float stops must be special ordered with 316 SS collars instead of grip rings.

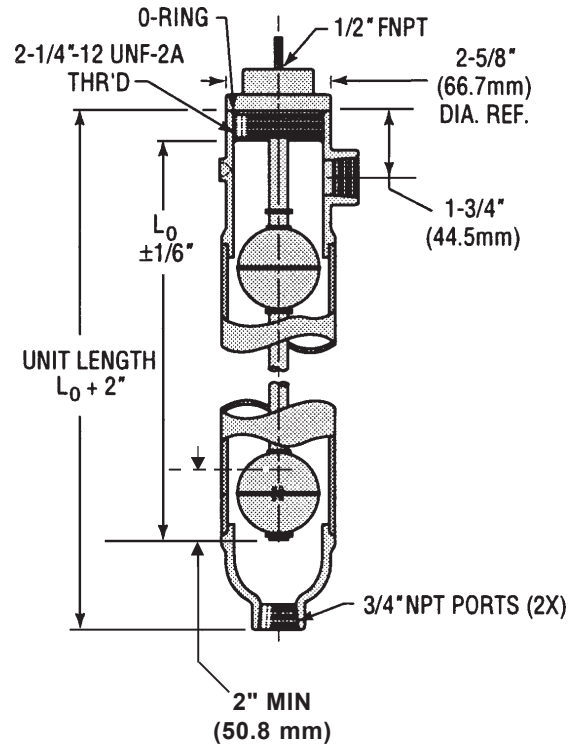

#### Standard Wiring Groups - Color Code

	SPST SWITCHES			SPDT SWITCHES				
	Group I	Group II		Group III		Group IV		
Wire Size	Note 2	Note 2		Note 2		Note 2		
Unit Com.	Black	None		Black		None		
	NO/NC	SW. Com.	NO/NC	NO	NC	SW. Com.	NO	NC
L1	Red	Red	Red	Red	Wh/Red	Red	Wh/Red	Wh/BIK/Red
L2	Yellow	Yellow	Yellow	Yellow	Wh/Yel	Yellow	Wh/Yel	Wh/BIK/Yel
L3	Blue	Blue	Blue	Blue	Wh/Blue	Blue	Wh/Blue	Wh/BIK/Blu
L4	Brown	Brown	Brown	Brown	Wh/Brn	Brown	Wh/Brn	Wh/BIK/Brn
L5	Orange	Orange	Orange	Orange	Wh/Orn	Orange	Wh/Orn	Wh/BIK/Orn
L6	Gray	Gray	Gray	Gray	Wh/Gra	Gray	Wh/Gra	Wh/BIK/Gra

- Notes:**
1. Shaded area designates UL-recognized wiring configurations.
  2. Non-UL-recognized units (unshaded areas) use #22 AWG, 24" L., Teflon lead wires.
  3. Units with 100 VA switches are not UL-recognized or CSA-listed.

#### LS-800 (Type 5) - Float Types

Float Material	Buna N		316 Stainless Steel	
Float Dimensions				
Part Number	10558		14569	15666
Operating Temperature	<u>Water:</u> to 180°F (82.2°C) <u>Oil:</u> -40°F to +230°F (-40°C to +110°C)		-40°F to +300°F (-40°C to +148.9°C)	
Min. Media Specific Gravity	.55		.80	.75
Pressure Rating (PSI, Max.)	Brass	100 @ +70°F (21.1°C)		
	316 S.S.	150	750	300

A single float type is selected for use at all actuation points.

**- Standard Single Level Units -**

**- Specifications -**

Operating Temperature	-40°F to 300°F (-40°C to 148.9°C)
Pressure Rating	P/N 167810: (500 psig Max) P/N 167811: (750 psig Max)
Electrical Termination	No. 18 AWG, 24" L, Polymeric Lead Wires
Approvals	U.L. Recognized File No. E45168 CSA Report LR 30200
Switch Operation	Selectable, N.O. or N.C. by Inverting Float On Stem
Mounting Attitude	Vertical with Lead Wires Up
Switch	20 VA (Pilot Duty)

**Typical Wiring Diagrams**

SPST, N.O. or N.C.

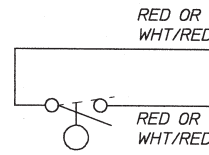

CIRCUIT CONDITION DRY

SPDT

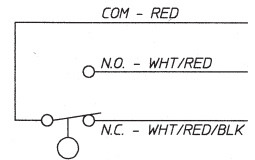

CIRCUIT CONDITION DRY

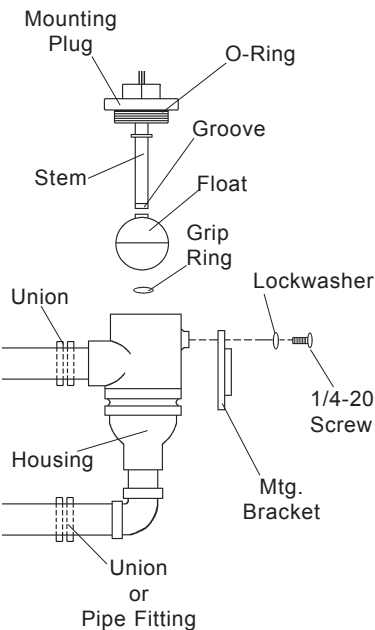

Standard single level units are supplied with SPST switch operation, N.O. (Dry).

To convert operation to N.C. (Dry): Remove level switch unit from housing, remove lower grip ring and invert float on unit stem. Reinstall lower grip ring into groove and reinstall level switch unit\*\* in housing.

\*\*Clean or replace O-ring on mounting plug (if required) before reinstalling float/stem assembly in housing. Mounting plug must be installed flush with housing.

**Note**  
Switch operation can be selected without disturbing installation of unit on tank.

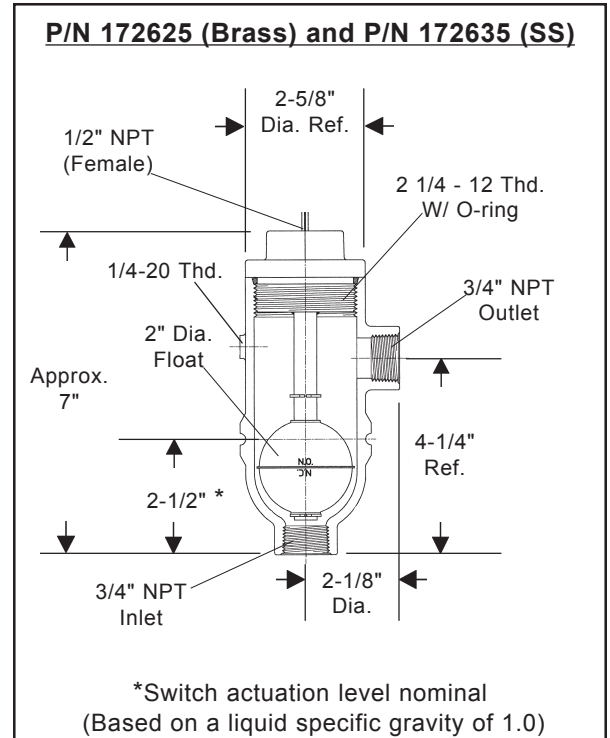

**Maintenance (All Units) . . .** An occasional "wipe-down" cleaning is the only maintenance normally required.

**Important Points!**

Product must be maintained and installed in strict accordance with the National Electrical Code and GEMS technical brochure and instruction bulletin. Failure to observe this warning could result in serious injuries or damages.

An appropriate explosion-proof enclosure or intrinsically safe interface device must be used for hazardous area applications involving such things as (*but not limited to*) ignitable mixtures, combustible dust and flammable materials.

\*\*\* Warning: To prevent ignition of flammable or combustible atmospheres, disconnect power before servicing.

Pressure and temperature limitations shown on individual catalog pages and drawings for the specified level switches must not be exceeded. These pressures and temperatures take into consideration possible system surge pressures/temperatures and their frequencies.

Selection of materials for compatibility with the media is critical to

the life and operation of GEMS level switches. Take care in the proper selection of materials of construction; particularly wetted materials.

Life expectancy of switch contacts varies with applications. Contact GEMS if life cycle testing is required.

Ambient temperature changes do affect switch set points, since the specific gravity of a liquid can vary with temperature.

Level switches have been designed to resist shock and vibration; however, shock and vibration should be minimized.

Liquid media containing particulate and/or debris should be filtered to ensure proper operation of GEMS products.

Electrical entries and mounting points may require liquid/vapor sealing if located in an enclosed tank.

Level switches must not be field repaired.

Physical damage sustained by the product may render it unserviceable.



**Gems Sensors Inc.**  
One Cowles Road  
Plainville, CT  
06062.1198

tel 860.747.3000  
fax 860.747.4244