

Eletta Flow Monitor

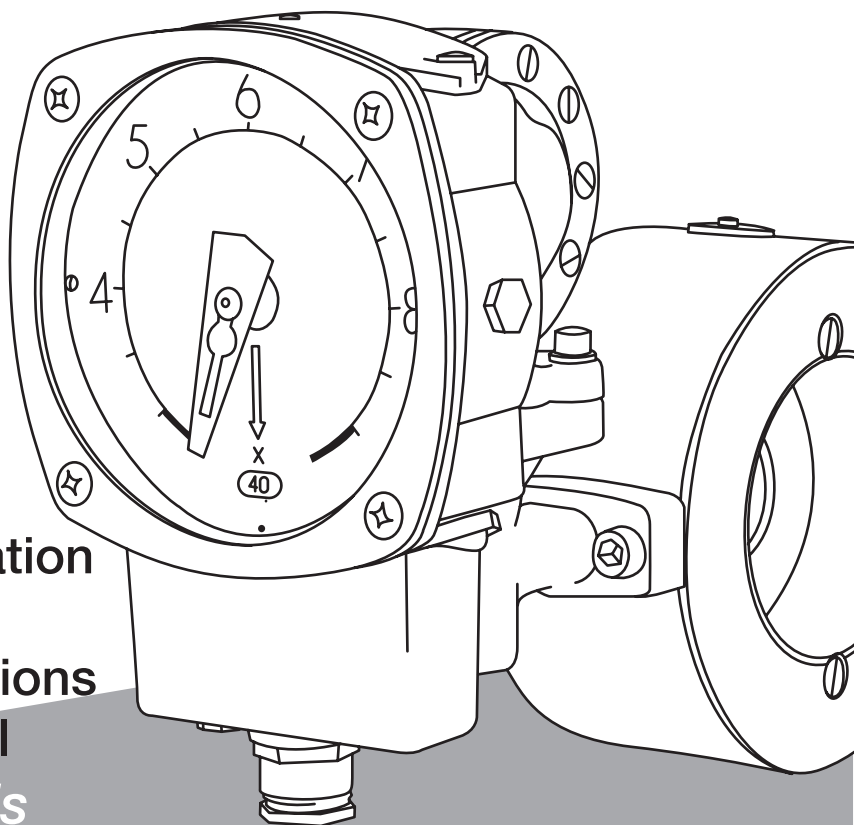

**Installation
and
Operations
Manual**

Models

*S2, S25, S02 and
S05*

ELETTA

FLOW MONITORS

Please note that this manual is available as a PDF-file on our website www.eletta.com along with other information such as technical leaflets and application reports.

This gives you the option either to print out the desired publications or watch it on the screen. Of course this also enables you to benefit from the use of modern software.

For instance you can adjust the size of the image to suit your specific need.

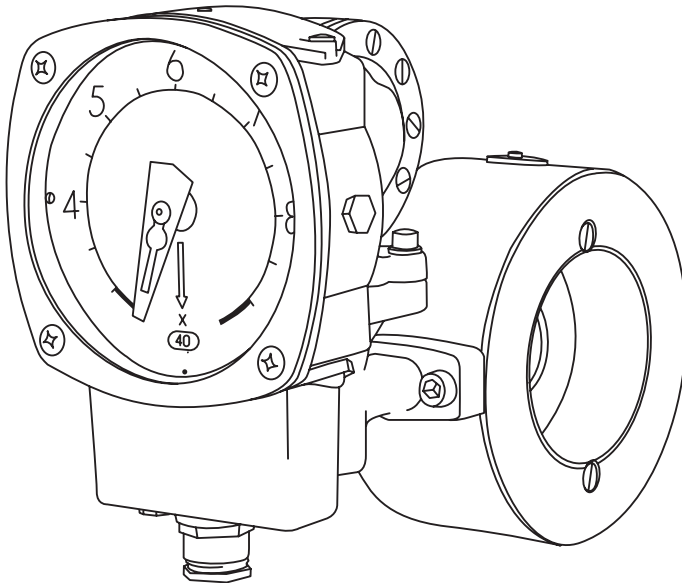

Notice of Proprietary Rights

This manual contains confidential technical data, including trade secrets and proprietary information, which is the property of Eletta Flow AB, Sweden.

These data are disclosed to you under the permission that you use it with limits within your company only, not including manufacture or processing uses.

Any other use is strictly prohibited without prior written permission from Eletta Flow AB, Sweden.

Customer Service

Our Customer Service Center is available to answer any of your commercial or technical questions at our normal office hours, 8.00 to 16.30 C.E.T. (8 a.m. to 4:30 p.m. Central European Time) The switchboard is manned 7.00 to 19.00 (7 a.m. to 7 p.m. C.E.T.) Before and after normal office hours on Monday to Friday, you can leave a message to the person at the switchboard and our Customer Service staff will contact you later. Questions and inquiries will be dealt with immediately over the phone or through fax and e-mail. The above hours are not valid at National Holidays or other occasions when production is closed.

Eletta has an International Network of Authorized Distributors, who are able to give you both technical and commercial assistance with our Products. Please see www.eletta.com

As we have tried to write this manual as carefully and comprehensive as possible from the beginning, we understand that you can still run into problems, which are not clearly described in this manual. In the unlikely event of such an incident, we kindly ask you to make sure that you go through the manual carefully, before contacting our Distributors or Eletta AB in Sweden. This is to save valuable time for any of us involved in the Eletta Products, as it is sometimes easy to overlook a specific sentence in the manual. If you after doing this still are not able to solve the problem, our Customer Service staff, at the below numbers and addresses, are more than happy to help you. You will also find useful information about our Products and organization on our homepage, which you can find at the address below.

This is how you can reach us:

Via Phone: +46 8 603 07 80 (Orders & Inquiries)
+46 8 603 07 70 (Switchboard)

Distributors: See www.eletta.com

Via Fax: +46 8 646 10 40

Via Mail: Eletta Flow AB
P.O.Box 5084
SE-141 05 Kungens Kurva, SWEDEN

Via e-mail: info@eletta.com

Website: www.eletta.com

Contents

1	General Information	5
1.1	Description	5
1.2	Specifications	6
2	Installation	10
2.1	Unpacking.....	10
2.2	Procedures before Installation	10
2.3	Installation of the Pipe Section	11
2.4	Separate mounting of the Pipe Section and Control Unit	12
2.5	Installation and changing the Control Unit	14
2.6	Pressure Drop	16
2.7	Electrical Installation	18
3	Operation	19
3.1	Principle of operation, DP-Flow Measurement	19
3.2	Change of Flow Range	19
3.3	Adjustment of switch point, S2 and S25	21
3.4	Change of Flow Direction	22
3.4.1	Flow Direction Selector (from January 2013).....	22
3.4.2	Flow Direction Selector (until December 2012)	23
3.5	Change of Dial Orientation.....	24
4	Trouble shooting	25
4.1	Verification of Flow.....	25
4.2	Electrical connections.....	26
4.3	Spares.....	27
5	Distributors	28
6	Tables	29
6.1	Measuring Ranges	29
6.2	Weight and Dimensions	30
7	Spare Parts	31
7.1	Exploded Drawing S-GL/FA.....	32
7.2	Exploded Drawing S-GSS/FSS	34

General Information

1.1 Description

The Eletta Flow Monitor is used to control and measure flow of liquids and gases in pipes from size 15 mm to 500 mm (larger pipes as an option). They have been manufactured for over 65 years and are well known for its reliability. They are used where operational safety demands, efficient supervision and rugged installation is needed, all over the world. Eletta Flow AB in Sweden is certified according to ISO9001 and ISO14001.

The Eletta Flow Monitor is based on the proven and dependable differential pressure principle, using interchangeable orifice plates for different measuring ranges. The Flow Monitors are working with two different differential pressure ranges, i.e. 50 – 200 mbar for the S2/S02 and 22 – 550 mbar for the S25/S05, depending on the desired and ordered flow range. The same goes for our models; V1 and V15, D2 and D5 and R2 and R5. Due to the working principle of the instrument, it is of utmost importance that the installation instructions (chapter 2) are followed carefully in order to get the proper function of the instrument.

The Eletta Flow Monitor models S2/S02 and S25/S05 will give you an accuracy of $\pm 5\%$ F.S. (Full Scale) if installed in the right way. (See chapter 1.2 “Specifications”, for complete information)

The Instrument consists of two parts mainly i.e. the Pipe Section and the Control Unit. The Pipe Section is the part that is to be mounted in the process pipe and the Control Unit is mounted directly (standard) or remote on/to the Pipe Section. The Control Unit is giving you the Flow information and also contains the SPDT contacts.

The Pipe Sections are available in different process connections with the following standards;

Threaded connections in BSP or NPT from 15 mm ($1/2''$) to 40 mm ($1\ 1/2''$) depending on the chosen material of construction.

Flanged (wafer) connection from DN15 /PN16 (ANSI $1/2''/150$ lbs) to DN 500/PN16 (ANSI $20''/150$ lbs) depending on the chosen material of construction. The DIN-standard flanged units are colored *blue*, the ANSI-standard units are colored *green* (>50 mm < 100 mm) for easy recognition in the field.

The Control Units S02 and S05 have a local readout and S2 and S25 are also

equipped with two independent adjustable alarms (micro switches) which can be set for low and high flow alarm. The readout has a scale, which shows you the ordered flow range with a multiplier as a standard. The standard scales have the following designations; for S2/S02 the scale goes from the number **4** to **8** (1:2 turndown). This is the value that you have to multiply the small multiplier (sticker) figure at the bottom of the scale with, in order to read the actual flow in the values you have ordered i.e. liters/min, m³/hours, USGPM. etc. (also shown at the bottom of the scale) For the S25/S05, the scale goes from **1** to **5** and hence, this is the value you use together with the multiplier at the bottom of the scale, to read the actual Flow through the Monitor.

The Control Unit can also be fitted with a special ordered scale (direct reading scales) as an option, for example; l/min, m³/h, USG/min etc. for easy reading and then you have no multiplier at the bottom of the scale.

1.2 Specifications

The *only* flow difference between the S2/S02 and S25/S05 is the turn down of the flow range i.e. the S2/S02 has a **1:2** turn down (for example; 50 –100 l/min) and the S25/S05 has a turn down of **1:5** (for example; 20 – 100 l/min).

Accuracy: <+/-5% F.S (full scale) within 20-80 % of the chosen Flow range
<+/-10% F.S.(full scale) within 100% of the chosen Flow range

The accuracy stated is achievable if the installation instruction is followed given in this manual. It is recommended that you always chose the Flow Range of the Flow Monitor so that the normal flow is in the middle of the Monitor Flow Range. Make sure that the expected alarm set points are within the chosen flow range. *For example:* If you have a flow of 110 l/min maximum and the normal Flow is at 90 l/min, chose the Eletta Flow Monitor S2 with a Flow Range of 60–120 l/min. This will give you the highest accuracy since your flow is in the middle of the Monitor Flow Range and give you a lower pressure loss.

Repeatability: < 2 %

Pressure: Max: 16 bar, (232 PSI), higher test pressure as an option.
Min: A line pressure of apx.: 0,7 – 1,0 bar (10 – 14,5 PSI) is required for proper operation.

Temperature: Control Unit
–20°C to 90°C (–4°F to 200°F), standard

–20°C to 120°C (–4°F to 250°F), optional

The lower temperature is not valid for Monitors equipped with FPM soft parts. FPM is limited to –5 °C (23 °F).

Higher process temperature with remote installation of Control Unit (*separate mounting, see section 2.4*)

These temperature limits are valid for models S2 and S25 (*with micro switches*)

Temperature limit for S02 and S05 is –20°C to 120°C (–4°F to 250°F). Pls note the FPM soft part remark above, which is valid also for S02/S05 models.

Pipe Section: The pipe sections are equipped with spacers (holding the orifice plate) made of Polyamide plastic (PA) material and they can handle liquid/gas temperature up to 150 °C (300°F).

For higher process temperature, we recommend to use the stainless steel pipe section, which has no spacers.

Dial: 120 mm diameter with mechanical pointer and a linear scale.

Front glass: Acrylic

Process

connection: DN15 – 40 (1/2” – 1 1/2”) for GL-models

DN15 – 25 (1/2” – 1”) for GSS -models

DN15 – 400 (1/2” – 16”) for FA-models

DN15 – 500 (1/2” – 20”) for FSS-models

Alarm/

Contacts: S2 and S25 have 2 (two) micro switch SPDT contacts, independently adjustable within the ordered Flow range.

S02 and S05 has no micro switch contacts included; only a dial for local indication of Flow.

Micro

switch spec: Contact surfaces are silver plated as standard.

Hystereses: +/-10%
 Voltage: max. 460 VAC
 Current: max. 15 A
 Inductive load: 15A @ 380 VAC
 0,03A @ 230 VAC
 5A @ 30 VDC
 Type: SPDT

For intrinsically safe (IS) applications, we recommend to order micro switches with gold plated contact surface, which are better suited for the voltage and current limitations in the Ex-regulations.

Protection

Class: As an option, xx micro switches is available (1HM1)

Control Unit: IP43 (NEMA 3R), standard
IP65 (NEMA 4x), optional
Aluminum alloy, alodine and epoxy polyester coated. 3 cable glands included (PG16/PR22,5)

Material; Diaphragm housing and pipe section:

Type GL: De-zincificated brass, CW602N, EN12420

Type GSS: Seaworthy stainless steel 1.4527

Type FA: Housing: De-zincificated brass, CW602N, EN12420
Pipe section: <DN50 (ANSI 2") Bronze CC491K / EN1982
>DN50 (ANSI 2") Painted cast iron, GG25 / DIN1691

Type FSS: Housing: Seaworthy stainless steel 1.4527 / EN10283
Pipe section: Stainless steel 1.4435

Material

diaphragm: Textile reinforced Hydrated Nitrile rubber (HNBR), standard on all models except stainless steel.
Textile reinforced EPDM rubber, optional for all models
Textile reinforced Fluorinated rubber, FPM, standard in stainless steel models, optional for others.

Material, O-rings and other

soft parts: Follows the Diaphragm materials.

Spacer: The spacer holds the orifice plate inside the pipes section and they are made of Polyamide plastic (PA) as a standard. Max.li-liquid/gas temperature is 150°C (300°F).

Explosion**Proof:**

The Flow Monitor itself is not approved as a complete instrument according to EU Hazardous Area EX-regulations.

CE-**approvals:**

The Eletta Flow Monitors conforms with the EU directive for low voltage no: 72/23/EEC (EN 60 204-1, Part 1.) We refer to the certificates issued, which will be sent to you upon request. They can also be on www.eletta.com.

PED-**Directive:**

Complies with applicable parts in Pressure Equipment Directive 97/23/EC. Conformity assessment has been performed according to module A. Internal production control combined with module A1. Internal manufacturing checks with monitoring of the final assessment, for category 2. Performed by Inspecta AB, Notified body No. 0409. PED Declaration of conformity will be sent to you upon request and are also available on www.eletta.com.

Approvals:

The micro switches, cables and terminal blocks are approved according to CSA.

2.1 Unpacking

We appreciate that you have decided to purchase our Products and we would like to ask you to begin the installation by checking your delivery against the Packing List. Please make sure to check the box for external damages before opening. If you find external damages, which have also led to damages to the Flow Monitor inside, you should contact the forwarder/shipper to claim replacement (or the cost of replacement). Check the Monitors' identification tag against your purchase order to make sure you have got the right articles with the right specifications.

All Monitors are individually packed in plastic bags and put into the box either two by two or individually in each box. The plastic bag is to prevent foreign particles to get inside the Pipe Section, which could prevent proper function of the Flow Monitor after the installation.

The box is made from recycled environmental friendly material and we kindly ask you to deal with the waste material in a way that will have as little impact on the environment as possible.

2.2 Procedures before Installation

Note!!! Before any installation or maintenance work, disconnect all electrical power!

Please check that you are going to mount the Monitor at the lowest point in the piping system if you are measuring liquids and at the highest point if you are measuring gases. Also check if the planned flow direction in the system matches the one indicated on the Monitor. There is a red flow direction arrow on the outside of the pipe section (not the Stainless Steel models which have a marking engraved on the side). If you find this to mismatch, we refer to section 3.4 "Change of Flow Direction", to adjust the internal flow director in order to match the desired flow direction. Change of the flow direction on the Stainless Steel Pipe Sections (FSS/GSS) is not possible in the field without ordering a new Pipe Section and we kindly ask you to contact your local representative or Eletta Flow AB, Sweden for help.

Check that the pipe section has the right threads or the right flange standard to match your piping or counter flange.

If you are using the separate/remote execution i.e. Pipe Section and Control Unit installed in different locations, please check the plastic hoses for any da-

mages or holes that can prevent proper function. The plastic hoses should not be used in temperatures over 90°C (194 °F). If your application temperature exceeds this temperature/pressure, we recommend to use copper or stainless steel tubing, depending on the compatibility to the measured gas or liquid (see section 2.4)

2.3 Installation of the Pipe Section

Note!!! Before starting to install the Pipe Section, please make sure that the piping is not under pressure from flow of liquid/gas!

The pipe section can be installed in any desired direction, vertically or horizontally or angular and the direction arrow on the pipe section denote the direction of the flow. It is very important that the pipe section is mounted with the correct direction, as the function of the Flow Monitor otherwise will be prevented. The piping shall be rigid and free from vibrations and hoses connected directly into the Monitors should be avoided as much as possible. If you have weak piping we advise you to use the M6 mounting holes (only on GL - series) on the backside of the pipe section, to fasten the pipe section to a wall or a rigid bracket. The straight runs before and after the Monitor should not be too short, in order to avoid disturbances, which can cause the Monitor to show incorrect values. We recommend giving at least 10 - 15 diameters upstream and 5 diameters downstream. (Please see Fig. 1)

Recommended installation of Pipe Section

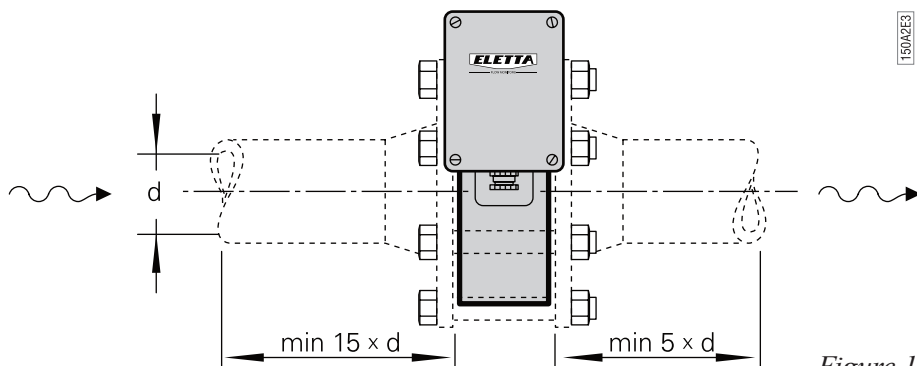

Figure 1

The reasons for this procedure is to achieve a stable flow profile inside the pipe and by doing so, get a true reading. Please be aware of the fact that it is practically impossible to predict when the flow is stable after disturbances in the piping, so this must serve as a guideline only. The straight runs must be

free from valves, bends or in/decreasing diameters. Any of these disturbances must be placed **before** and preferably **after** you start counting the straight runs.

If you are installing the threaded versions, GL and GSS-versions, please make sure that you are not using so called **”tube fittings”**. We have often seen them to have a much smaller inside diameter than the pipe section, even though the size of the thread match. This can create a jet stream of the fluid/gas, which will cause the differential pressure to be too low and you, will not get a good or accurate reading.

The following inside diameters apply for the threaded Pipe Sections:

GL-and GSS 15 = **16 mm**

GL-and GSS 20 = **21 mm**

GL-and GSS 25 = **26 mm**

GL-40 = **41 mm**

Make sure that the Control unit, if mounted directly on the Pipe Section, is placed on top of the Pipe Section and not under to prevent particles in the fluid to collect in the diaphragm housing. Please use a filter in the pipeline if you suspect the fluid to contain particles.

The flanged models, FA and FSS-versions, must be aligned with the counter flange and not placed in stress by tightening the bolts uneven. The flanged models come with a gasket and we recommend using this, as it is dimensioned to suit the installation. Please see to that the gasket is properly aligned and not disturbing the flow. It is also of utmost importance that the connecting pipe and flange is of the same diameter (inside) and standard as the pipe section. A mismatch can cause an erratic or incorrect reading of the flow. If needed, please support the Flow Monitors with rigid brackets. There is no problem in attaching the brackets directly to the Flow Monitor (see above), but we recommend mounting them in the pipeline downstream and upstream to avoid unnecessary stress in the installation area.

2.4 Separate mounting of the Pipe Section and the Control Unit

Sometimes separate mounting of the Pipe Section and the Control Unit is requested due to vibrations, high temperature or lack of space. As the Eletta Flow Monitor is using the differential pressure caused by the orifice plate mounted in the pipeline and directs these two pressures via two individual

ports up to the Control Unit, it is also possible to separate the Monitor (Fig. 2) from the Pipe Section -GL/FA into two parts. The pressure is then lead through either plastic hoses or metallic tubing depending on the liquid, pressure and temperature.

As a standard, we supply 2x1,75 meter (5.74 feet) of PA plastic, Ø 6 mm (0,23 inch) hoses capable of handling 90°C (194°F) and 16 bar (232 PSI), together with two specially made adapters to be mounted on the Pipe Section and Control Unit respectively. If your application requires metallic tubing (copper or stainless steel) it has to be provided locally. If you are measuring a chemical liquid or gas, check with the supplier which material you should use in your tubing. Please make sure to use only 6 mm tubing in order to suit the tube fittings included in the delivery. There is no actual limitation in the length of the hoses or tubing, but we recommend placing the units as close as possible to each other, as this will help in troubleshooting and on-site calibration.

Note!!! The hoses/tubings must have the same length to avoid uneven pressure. If you mount valves (not included in delivery) in the pressure hoses/tubing, it will help you to easily shut them off and remove/exchange the Control Unit at full process pressure.

The Mounting of three-way/five-way standard valve (not included in delivery) will allow you to discharge any entrapped air/gas or condense and also provide the possibility to even out the pressure between the plus and minus leg for zero verification. Please follow the above "Installation of the Pipe Section" after you have mounted the adapter on to the Pipe Section. As you will use hoses/tubing to lead the pressure up to the Control Unit, it is possible to mount the Pipe Section in any direction, vertically or horizontally and with the pressure ports pointing up, down or to the side (*pls. see section 2.3*).

Separate mounting of Pipe Section and Control Unit GL/FA

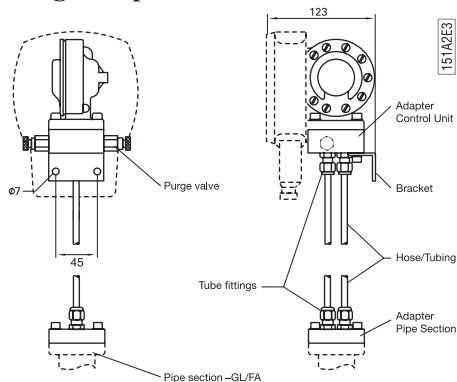

Figure 2

Separate mounting of Pipe Section and Control Unit GSS/FSS

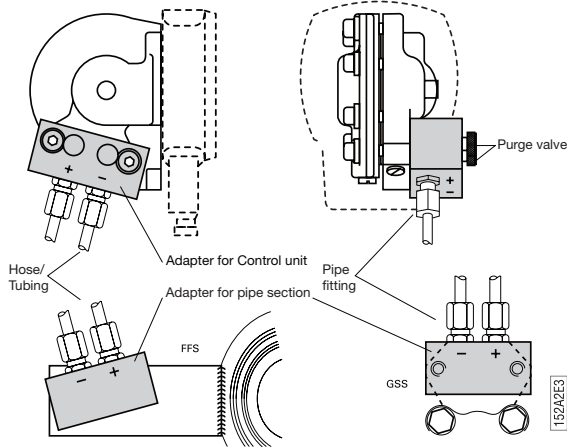

Figure 3

Find a suitable place for the Control Unit to be mounted. Use the supplied bracket to attach it to a wall, pipe or another steady and rigid support. To take advantage of the large and clear dial, the Control Unit should be clearly visible from a distance and easy accessible for maintenance if needed. Please plan this with respect to later mounted piping or other obstacles. Install the hoses/tubing, commencing with the Pipe Section. Check that you have enough length to cover the distance between the Pipe Section and Control Unit. The Pipe Section adapter has a (+) and (-) marking engraved and the adapter on the Control unit too. Please make sure to match (+) to (+) and (-) to (-) on the adapters. Press the hose/tube end into the coupling and tighten with care. Proceed to the Control Unit and repeat the above. When you fill up the system for the first time with liquid, please make sure that all entrapped air in the piping between the Pipe Section and Control Unit is removed. The air can otherwise, as it is a compressible media, cause faulty flow readings.

2.5 Installation and changing of the Control Unit

As all Eietta Flow Monitors are designed in sections to achieve a modular and versatile Flow Monitor, there is a possibility to upgrade/rebuild them and adding other features to your already installed Monitor, by changing the Control Unit or Pipe Section. If you, for example, would like to upgrade a **V**- or **S**-series with mechanical micro switches to a **D**-series including analog and/or frequency output, local front display and two independent adjustable relays or the other way around, this is easily done. The same applies to the **R**-series with analog and/or frequency output. You simply order a Control Unit with the flow

range you need, to get the right dial with the right multiplier or direct reading scale. When you order, you will get the Control Unit with the diaphragm housing included. Make sure you order the right material in the diaphragm housing and the soft rubber parts (diaphragm, o-rings and diaphragm lever) and you will get the Control Unit already tested and calibrated and ready to fit onto the Pipe Section, without any on-site adjustments or calibration. All Eletta DP Flow Monitors are working with the same differential pressure within their specific range (*Pls. see section 1.1*).

If you have a Pipe Section designated; **-GL or GSS (-FSS)**, **start with making sure that there is no pressure in the system**, as these Pipe Sections do not have any internal shut-off valves for isolating them from process pressure. **Turn the electric power supply off** and then disconnect the cables from the micro switch electric terminal. If you have a Pipe Section designated; **-FA** you will find the included shut-off valves under the brass elbow, which connects the Control Unit to the Pipe Section.

Turn them counter-wise until you feel the end position and this shuts off the pressure up to the Control Unit and you can easily remove this. If you have a Pipe Section designated; **-FSS**, there is an option to buy this with a shut-off manifold, but it will not come as a standard.

On the -GL Pipe Section; loosen the four (4) hexagon screws that hold the diaphragm housing (do not remove the blue housing at any time) to the Pipe Section. Replace the flow direction selector (3.4.1 and 3.4.2) if damaged, or if other material is required. *Install the new Control Unit and tighten the four (4) hexagon screws firmly again.*

On the -GSS Pipe Section; loosen the two (2) hexagon screws that hold the diaphragm housing and replace the O-rings to the right material, if necessary. *Install the new Control Unit and tighten the two (2) screws firmly again.*

On the -FA Pipe Section; shut off the two (2) included valves as per above and then untighten the four (4) screws which hold the diaphragm housing. Replace the flow direction selector (3.4.1 and 3.4.2) if damaged, or if other material is required to the pipe section. Install the new Control Unit and tighten the four (4) screws firmly again. *Do not forget to open the two (2) shut-off valves again, in order to get a proper function!*

On the -FSS Pipe Section; If you have a Monitor that has a shut-off manifold, you can close the two (2) valves to get the diaphragm housing non-pressurized. Otherwise, start with checking that there is no pressure in the pipe system and up to the diaphragm housing. Loosen the two screws that hold the diaphragm housing and replace the O-rings to the right material, if necessary.

Install the new Control Unit and tighten the two (2) screws firmly again. If a shut-off manifold is installed; do not forget to open up the two (2) shutoff valves again, in order to get a proper function of the Flow Monitor.

Connect the electrical cables according to your new Control Unit's possibilities and for detailed information regarding wiring, please see section 2.7 "Electrical installation".

2.6 Pressure Drop

The Eletta Flow Monitor is a differential pressure measuring device and therefore it creates a certain pressure drop when in function. There are two different types of Pressure Drop's involved, **actual pressure drop** and **permanent pressure drop**. Below we will explain the difference between these two: When the orifice plate mounted in the Eletta Flow Monitor reduces the flow area inside the pipe system, a pressure drop over the orifice is created. This is what we call **actual pressure drop**. *Please refer to chapter 1.1 "Description" for actual pressure drop (differential pressure span).*

The calculation of the flow is using this pressure drop to calculate the actual flow value (*see calculation below*). **The actual pressure drop** is a temporary pressure state and the Eletta Flow Monitors are working within this differential pressure created within the Flow range of the Monitor. When the flow has passed the Monitor, the pressure is then trying to get back to its original pressure and normally after 10 - 15 times the inner diameter of the pipe, the flow becomes linear and fully developed. This is a normalized flow but due to friction losses over our Flow Monitor, the pressure will not be able to reclaim all the energy (*pressure*). This is what we call **permanent pressure drop**.

The permanent pressure drop can be calculated approximately by $\Delta\rho(\text{ppd}) = \Delta\rho(\text{apd}) \cdot (1-\beta^2)$, where the symbols represent:

$\Delta\rho(\text{ppd})$ = permanent pressure drop

$\Delta\rho(\text{apd})$ = actual pressure drop (see formula below "actual pressure drop graph" for calculation)

β = **d/D** ratio (ratio between bore and inner diameter of the pipe).

This means that for the normal β range (0.2 - 0.7) a typical **permanent pressure drop** ranges from 0.96 $\Delta\rho$ and 0.51 $\Delta\rho$ can be expected.

Example:

For the Eletta Flow Monitor S2-GL15 with a flow range of 10 - 20 l/min, the following example can be used for how to calculate the $\Delta\rho(\text{ppd})$ permanent pressure drop) at 15 l/min for the said Monitor:

$$d = 10,2 \text{ mm}$$

$$D = 16,0 \text{ mm}$$

This gives $\beta = 10,2/16,00 \Rightarrow \beta = 0,6375$ and $(1-\beta^2) = 0,594$

Furthermore, in order to use this β -value in the above formula, we need to determine the $\Delta\rho(\text{apd})$. We can either use the "Actual Pressure Drop Graph" (fig. 4) for an approximate value or for intermediate values we can use the formula below the graph (fig. 4). If we use the formula for calculate the $\Delta\rho(\text{apd})$ at 15 l/min we will get;

$$\Delta\rho(\text{apd}) = (15/20)^2 \cdot 200 \text{ mbar} \Rightarrow 112,5 \text{ mbar}$$

In order to finally get the permanent pressure drop, we use the above described formula: $\Delta\rho(\text{ppd}) = \Delta\rho(\text{apd}) \cdot (1-\beta^2)$ and put in the values we have:

$$\Delta\rho(\text{ppd}) = 112,5 \cdot 0,594 \text{ mbar} \Rightarrow 66,82 \text{ mbar}$$

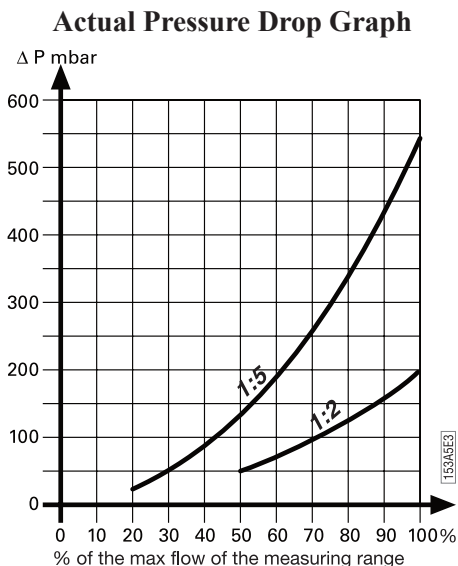

Figure 4

$$\Delta\rho(\text{apd}) = (Q/Q_{\text{max}})^2 \cdot 200 \text{ mbar} \quad \text{for turn down ratio of 1:2}$$

or

$$\Delta\rho(\text{apd}) = (Q/Q_{\text{max}})^2 \cdot 550 \text{ mbar} \quad \text{for turn down ratio of 1:5}$$

Q = actual flow

Q_{max} = maximum flow of the Flow Monitor (according to the installed orifice plate)

The Pressure loss curves in the graph (fig. 4) must serve as a guideline.

2.7 Electrical Installation

Note!!! An authorized professional person should make all electrical installations.

This section is not valid for the models **S02** and **S05** as these are Monitors without any micro switches installed and work without the need of electrical power. Before you connect any cables, please make sure that you have the right power supply within the specifications (*see section 1.2 “Specifications”*).

All terminal block connections are to be made through the included cable gland PR22,5/PG16 (and please note that you can have two alternative mountings of the cable gland depending on what side you want to enter with the cables). ***If you install the Flow Monitor in an Ex-hazardous area, please make sure to follow local installation procedures and regulations.*** The terminal block connections are described in *fig.5* below. A grounding screw is to be found at the side of the terminal block.

Before any circuit is connected/disconnected, make sure that all power is off!

Setting of high/low flow alarm for the S2/S25 (tool normally placed under top lid)

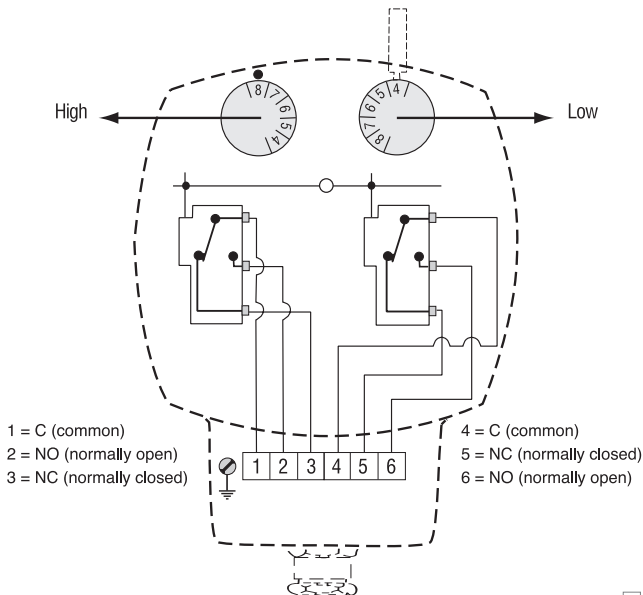

The wiring diagram shows the switching function when the flow is zero or below the lower setpoint.

1771A2E3

Figure 5

Operation

3.1 Principle of operation, DP-Flow Measurement

The Eletta Flow Monitor's function is based on the proven and dependable differential pressure principal, using interchangeable sharp-edge orifice plates for different measuring ranges. This is perhaps the oldest and most widely used principle for flow metering, mainly because of its simplicity, its relatively low cost and high volume of research data available for predicting the Flow Monitors behavior. In the Pipe Section, a fixed area flow restriction (the orifice plate) causes a pressure drop, which varies with the flow rate. This pressure drop has a high and a low pressure, which is lead through two channels from each side of the orifice plate, to the Control Unit. By measure the pressure drop allows flow rate measurement by means of a mathematical formula. A short form of the calculation can be described as $Q = \sqrt{\Delta p}$.

In most Eletta Flow Monitors, the differential pressure is sensed and measured mechanically via a rubber diaphragm and linked to an outside of the process liquid/gas, mechanism. This mechanism transforms the movement into a Flow rate value shown on the dial. All the Eletta Flow Monitors are tested and approved according to the European CE-mark regulations. (Pls. contact your Distributor or Eletta Sweden for copy of certificate or go to www.eletta.com).

3.2 Change of Flow Range

The Eletta Flow Monitor features an orifice mechanism that does not require recalibration after replacement and can easily be rebuild in the field to change the flow range to another from the flow rate ordered. This is valid for all Pipe Sections **except the GSS/FSS-models** where you have to order a completely new Pipe Section, as the flow selector is an integrated part of the orifice plate. The orifice plate inside the pipe section is the only part in the liquid/gas that has to be changed. You can order and change any flow range that suits your specific application, as long as the new flow rate falls within the total possible span for the actual Flow Monitor (*see section 6.1 page 29*).

In each case of rebuilding the flow Monitor in the field, we kindly ask you to consult Eletta or your local Distributor for advise of the right orifice plate before ordering.

First empty the piping system so it is un-pressurized and has no flow!

For threaded model -GL:

Untighten the bolts that hold the Pipe Section between the flanges in the piping (do not remove the threaded parts from the piping). Remove only the number of bolts necessary to pull the Monitor from the piping, normally it takes only one bolt from the highest position, to get the Monitor out. Take out one of the spacers that holds the orifice plate. Change the orifice plate to the new ordered orifice plate and remember that you can install it in any direction. Reinstall the spacer that holds the orifice in place inside the Pipe Section. Install the Monitor in the piping system again and tighten the bolts firmly to avoid leakage.

For threaded model -GSS:

In this model there is no loose replaceable orifice plate and therefore it is necessary to change the complete orifice section with holder, to achieve a new flow range.

Please follow the above instructions for the -GL model for dismantling the whole orifice plate with holder. Remove the Control Unit from the old Pipe Section (orifice section) and install this to the new Pipe Section. Remount the Flow Monitor into the piping system again and tighten the bolts firmly.

For flanged model FA-:

Follow the procedure above to loosen the pipe section from the counter flanges in the piping system, but note that the spacers are held in place with two screws, which has to be untightened before removal

For flanged stainless steel model FSS-:

In this model there is no loose replaceable orifice plate and therefore it is necessary to change the complete Pipe Section to achieve a new flow range. Follow the procedure above to loosen the Pipe Section from the counter flanges in the piping system. Remove the Control Unit from the old Pipe Section (orifice section) and install this to the new Pipe Section. Remount the Flow Monitor into the piping system again and tighten the bolts firmly.

Always check that no gaskets will interfere, by misaligning, with the flow when installing the Flow Monitor.

Type plate and measuring constant

When you change the orifice plate in order to get a new flow range, it is necessary to change the identification plate to a plate with the new range marked. This identification plate comes together with the orifice plate when you

order an orifice plate separately. You also have to attach another multiplication label to the dial to suit the new range and this label also comes with the new orifice plate.

Dial

If you have a direct reading dial installed instead of our standard, a new dial must be specified and ordered with the new orifice plate.

3.3 Adjustment of switch point, S2 and S25

All the Eletta Flow Monitors are tested and calibrated according to the customers' orders before shipping. If the customer does not specify a desired switch point for the flow alarm, the S-series Monitor's micro switches are preset to trip at the min- and max flow value. ***Please note!!*** We have calibrated each Flow Monitor in our flow rig and set the switches according to the Flow values we achieve in the rig under good conditions. We must stress that under actual field conditions, the flow profile can be different from the one in our flow rig depending on valves, hoses, bends or other obstructions and therefore the switching can be off from our preset values. There is a possibility to adjust the switch/alarm points in the field by adjusting the micro switches' position mechanically. To readjust, remove the two screws that hold the cover at the top of the blue housing. The two adjusting dials are then visible through the opening. Underneath the removed cover, you will find a small tool necessary to use in order to change the adjusting dials position.

The adjusting dials are marked the same as the scale in the front and this marking can be used to approximately find the right switch/alarm point for the actual application. Put the tool inside the drilled hole on the top of the adjusting dial and gently move the dial sideways to the desired position. If the two adjusting dials are set to the same position, the micro switches will trip at the same time. If possible, use the left adjusting dial for the high flow alarm (higher end of the scale) and the left for the min. flow alarm (the lower end of the scale), in order to get the best accuracy. If you use the alarms the other way around, the spring mechanism inside the diaphragm housing will be affected with lower accuracy as a result, so please try to avoid that.

Repeat the procedure for the next adjusting dial and then put the tool back in its bracket at the cover.

If you have the possibility to check against a flow meter in the system, you will get the best on site adjustment of the switch point.

Reinstall the cover at the top with the two screws and start up the process again.

3.4 Change of Flow Direction

For GL-models, first empty the pipe system so that it is un-pressurized and has no flow!

For FA-models, use the shut-off valves, see section 2.5

At the time of ordering, you must specify in which direction the Flow Monitor shall be mounted i.e. from which side is the flow entering the Pipe Section and how you would like to read the scale. (Please refer to fig. 6 below for alternatives.) If, for some reason, the Flow Monitor is ordered with the wrong flow direction, it is possible to change this in the field.

3.4.1 Flow direction Selector (from January 2013)

GL- and FA-models are delivered with a flow direction selector that can be used for both directions.

To change the direction, loosen the four (4) hexagon screw, which hold the diaphragm housing to the Pipe Section. Remove the diaphragm housing and you will see the flow direction selector (it might have attached itself to the bottom side of the diaphragm housing). Replace the flow direction selector in the configuration for your system (see fig. 6).

Please also remember to turn the red arrow mounted on the Pipe Section (-GL and -FA models), to align with the new flow direction.

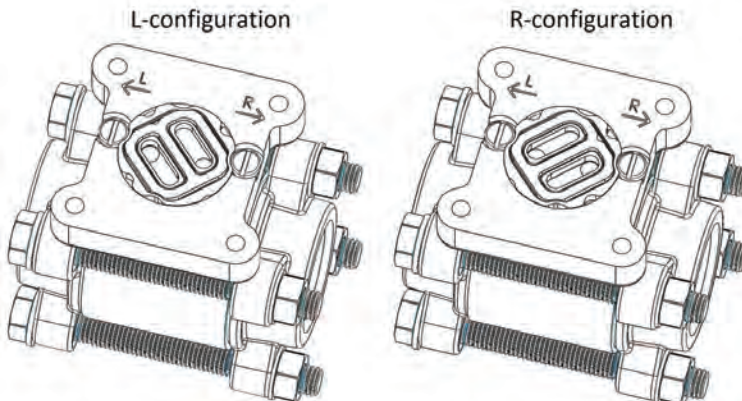

Figure 6

3.4.2 Flow Direction Selector (until December 2012)

For GL and FA models there are two flow direction selectors to choose from, the "R" and the "L" selector.

For mounting directions according to alternative A, C and F (see fig. 7), use the "R" selector. For B, D and E alternatives (see fig. 7), use the "L" selector. The flow direction selector must be ordered as a spare part, according to the right alternative.

To change the selector, loosen the four (4) hexagon screws, which hold the diaphragm housing to the Pipe Section. Remove the diaphragm housing and you will see the flow direction selector, which is held in place by two screws. Remove the screws and change the selector. Make sure that the four o-rings are mounted correctly to avoid leakage. Mount the diaphragm housing to the Pipe Section and tighten the four hexagon screws firmly.

Please also remember to turn the red arrow mounted on the Pipe Section (-GL and -FA models), to align with the new flow direction.

For -GSS and -FSS models we refer to section 2.2.

Dial orientation and ordering code

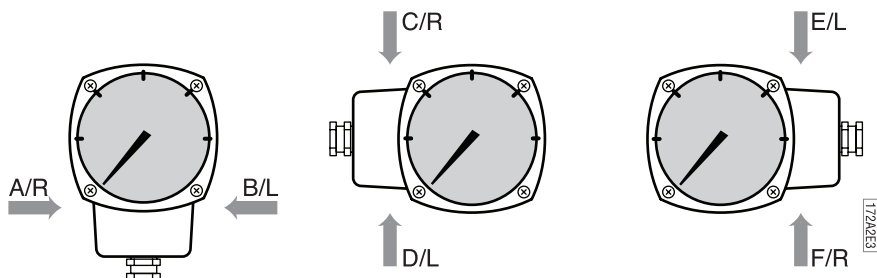

Figure 7

3.5 Change of Dial Orientation

As the Eletta Flow Monitors are not limited to a certain mounting position in the piping system, the large visible dial can be mounted in several positions to suit the application. (*please refer to fig. 7*). If you need to change the orientation in the field, please do as follows;

Note! Make sure that all electrical connections are set to power off before starting the following procedure!

Remove the front glass with the four screws that hold it in place. Push the pointer towards the dial and then upwards until the round hole in the pointer matches the spindle coming out from the mechanism and then remove the pointer. Undo the two screws that hold the dial and turn the dial 90° to the desired position and tighten the screws in the predrilled holes. Reinstall the pointer according to the new orientation with the reverse procedure from when it was removed.

The spindle and the pointer has a square fitting which make s it possible to install the pointer in four (4) different positions and make sure that you put it firmly in the right position for your application. When there is no flow through the Monitor, the pointer shall point to the beginning of the red part of the scale = zero position.

Note that a change of the mounting direction of the dial also can make it necessary to change the flow direction selector (see section 3.4).

Trouble shooting

4.1 Verification of flow

We would like to stress the fact that all the Eletta Flow Monitors are calibrated and adjusted individually on water in a specially purpose built calibrated flow rig in our workshop. This means that we have calibrated/adjusted the Monitors under reference conditions with enough straight runs before and after, always the same liquid, temperature, flows and pressure. If you find our Monitors to show another value compared to a reference meter on site, it can well be due to the fact that the reference meter has been calibrated under other reference conditions and that our Monitor have other conditions on site in the actual application, than we used under the calibration prior to shipping.

The Monitor is not showing any or the wrong value:

Is the Monitor mounted correctly with respect to the flow direction? Please check the arrow on the outside of the pipe section with the actual (true) flow direction For GL- and FA-models, check the flow direction selector inside the monitor. Make sure that it is corresponding to the true flow, see 3.4.

- Is there any flow in the pipe? And is it enough to create the needed Δp ?
- Do you have the right orifice plate for the application? Check the stamped values on the orifice plate. (pipe section model number and flow)
- If you are using compression couplings into the Monitor inlet, check that the inside diameter is enough to avoid the “nozzle” effect described above in section 2.3 and also check the table for the minimum correct inner diameter in the same section.
- Are there enough straight runs upstream and downstream the Monitor? (10 diameters upstream and 5 downstream.)

Do you have valves or bends in more than one plane within the above straight runs? If so, move the Monitor further away to achieve enough straight runs.

Under the above section 3.1 it is described how the Monitor creates the differential pressure. Eletta Flow Monitors work with two different Δp 's i.e. on the V1 and S2 units the Δp is always maximum 200 mbar and for the V15 and S25 units, the Δp is always maximum 550 mbar. This means that at maximum Δp the flow is always 100% in any Flow Monitor mounted on any pipe section.

This makes it very easy to move one control unit from one pipe to another Pipe Section on another pipe in order to check the function. It does not matter what size the pipe section has, as we always work with the same Δp on every pipe size.

To check if the Monitor is showing the right desired and ordered value, it is easy to remove the Flow Monitor from the pipe system and block the orifice plate and apply the correct maximum pressure at the inlet. If you apply for example **200 mbar** on the S2/S02series with a blocked orifice, the pointer should reach the last digit (8 for the S2/S02) on the front scale and if you have a direct reading scale installed, the pointer should reach the end value.

The same goes for a S25/S05 model, which should reach the digit 5 if you apply a pressure of **550 mbar**.

You can of course also verify the flow in the Eletta Flow Monitor versus another flow meter in the system or take the Monitor out and put in a flow test rig, if you have the possibility.

If the above is not the case there is a need to send the Monitor to the Distributor or directly to The Eletta Service department for control.

If you find process liquid/gas coming out of the Control Unit;

Most probably you will find a broken lever, the small stainless steel shaft going through a rubber sealing and it is attached to the diaphragm in the end. If you have exposed the Monitor to excessive pressure (over 16 bar/232PSI standard) or if the process liquid/gas is too aggressive to the rubber in the sealing, it can cause the sealing to break.

Please check the identification plate/tag on the Monitor and write down the serial number, flow range and liquid before ordering a new lever from your representative or us. If you have ordered a specially designed Flow Monitor i.e. if it does not follow our standard execution, it must be checked what kind of soft parts (diaphragm and seals) you have installed in the Flow Monitor. There are three different kinds of rubber to order (*see section 1.2 for details*) and we kindly ask you to provide us with the above information in order to help us ship you the right material.

4.2 Electrical connections

Please always see to that you are using the right voltage and current (*see section 1.2*) and that you have connected all the leads in a proper way (*see section 2.7*). If you open the cover on the Control Unit of the Monitors it is normally

very easy to see, if a component is broken/burned. If you find the micro switches are malfunctioning, it is possible to order new ones from Eletta Flow or your representative and replace them on site.

If you need to order a complete Monitor or a Control Unit for any reason, please check the identification plate/tag and write down the serial number, flow range and liquid and order a new Unit from us. We will ship you the complete Control Unit with diaphragm housing and you can then easily fit the new Control Unit to your existing Pipe Section with only four (4) screws, (*please see section 2.5 for details*).

4.3 Spares

We are proud to say that our Flow Monitors are well known for their long lifetime and robust construction but inevitably, it is sometimes needed to order spare parts. We refer to section 7 where you can find an exploded drawing showing all replaceable components included in the Flow Monitor.

If you have installed the Eletta S-series Flow Monitor in a very critical application, we recommend you to have a complete identically precalibrated Control Unit on stock, as it will only take removal of four bolts to change this. The Pipe Section consists of no moving parts and all copper alloy/steel material and it is very rare with a break down of this part.

Distributors

Eletta has appointed distributors around the world. You find more information about which distributor to contact on our website www.eletta.com or call our customer service.

Phone: +46 8 603 07 80

Fax: +46 8 646 10 40

Tables

6.1 Measuring Ranges

S2 and S02					
Dim. DN		lit/min	MC×(S2)		
1/2" DN 15	GL,GSS FA, FSS	0,4 – 0,8	0,1		
		0,6 – 1,2	0,15		
		1 – 2	0,25		
		1,6 – 3,2	0,4		
		2 – 4	0,5		
		2,4 – 4,8	0,6		
		3,2 – 6,4	0,8		
		4 – 8	1		
		6 – 12	1,5		
		8 – 16	2		
		10 – 20	2,5		
12 – 24	3				
16 – 32	4				
3/4" DN 20	GL,GSS FA, FSS	4 – 8	1		
		6 – 12	1,5		
		8 – 16	2		
		10 – 20	2,5		
		12 – 24	3		
1" DN 25	GL,GSS FA, FSS	8 – 16	2		
		10 – 20	2,5		
		12 – 24	3		
		16 – 32	4		
		24 – 48	6		
		36 – 72	9		
		40 – 80	10		

		FA, FSS	50 – 100	12,5	
		1 1/4" DN 32	FA, FSS	20 – 40	5
				28 – 56	7
40 – 80	10				
60 – 120	15				
80 – 160	20				
1 1/2" DN 40	GL, FA, FSS	20 – 40	5		
		28 – 56	7		
		40 – 80	10		
		60 – 120	15		
		80 – 160	20		

FA, FSS	100 – 200	25			
2" DN 50	FA, FSS	40 – 80	10		
		60 – 120	15		
		80 – 160	20		
		120 – 240	30		
		160 – 320	40		
2 1/2" DN 65	FA, FSS	60 – 120	15		
		80 – 160	20		
		120 – 240	30		
		160 – 320	40		
		240 – 480	60		
		280 – 560	70		
3" DN 80	FA, FSS	120 – 240	30		
		160 – 320	40		
		240 – 480	60		
		320 – 640	80		
		400 – 800	100		
4" DN 100	FA, FSS	160 – 320	40		
		280 – 560	70		
		400 – 800	100		
		600 – 1200	150		
		700 – 1400	175		
5" DN 125	FA, FSS	400 – 800	100		
		600 – 1200	150		
		800 – 1600	200		
		1000 – 2000	250		
6" DN 150	FA, FSS	600 – 1200	150		
		800 – 1600	200		
		1200 – 2400	300		
		1400 – 2800	350		
		1500 – 3000	375		
8" DN 200	FA, FSS	800 – 1600	200		
		1200 – 2400	300		
		1600 – 3200	400		
		2400 – 4800	600		
		2500 – 5000	625		
10" DN 250	FA, FSS	1600 – 3200	400		
		2000 – 4000	500		
		3200 – 6400	800		
		4000 – 8000	1000		

S25 and S05			
Dim. DN		lit/min	MC×(S25)
1/2" DN 15	GL,GSS FA, FSS	0,4 – 2	0,4
		1 – 5	1
		2 – 10	2
		4 – 20	4
		6 – 30	6
		8 – 40	8
3/4" DN 20	GL,GSS FA, FSS	4 – 20	4
		6 – 30	6
		8 – 40	8
1" DN 25	GL,GSS FA, FSS	6 – 30	6
		12 – 60	12
		16 – 80	16

	FA, FSS	30 – 150	30
1 1/4" DN 32	FA, FSS	8 – 40	8
		20 – 100	20
		40 – 200	40
1 1/2" DN 40	GL, FA, FSS	8 – 40	8
		20 – 100	20
		40 – 200	40
2" DN 50	FA, FSS	20 – 100	20
		40 – 200	40
		70 – 350	70
2 1/2" DN 65	FA, FSS	20 – 100	20
		50 – 250	50
		100 – 500	100
3" DN 80	FA, FSS	40 – 200	40
		80 – 400	80
		160 – 800	160
4" DN 100	FA, FSS	240 – 1200	240
		80 – 400	80
		160 – 800	160
5" DN 125	FA, FSS	80 – 400	80
		160 – 800	160
		250 – 1250	250
6" DN 150	FA, FSS	400 – 2000	400
		800 – 4000	800
		1000 – 5000	1000
8" DN 200	FA, FSS	400 – 2000	400
		600 – 3000	600
		1000 – 5000	1000
10" DN 250	FA, FSS	1500 – 7500	1500
		600 – 3000	600
		1000 – 5000	1000
10" DN 250	FA, FSS	1600 – 8000	1600
		2400 – 12000	2400
		600 – 3000	600

It is possible to order a lower measuring range than indicated in the table above for each pipe size, but not a higher one.

MC = Measuring Constant

6.2 Weight and Dimensions

S.--GL						
Type	D	A mm	B mm	C mm	E mm	Weight kg*
-GL15	R 1/2"	85	150	30	80	3,5
-GL20	R 3/4"	85	150	30	80	3,5
-GL25	R 1"	85	150	30	80	3,5
-GL40	R 1 1/2"	95	160	40	90	4,5

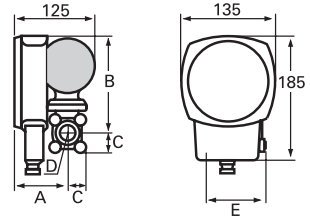

S.--FA					
Type	d mm	D mm	A mm	Width mm	Weight kg*
-FA15	16 (1/2")	53	160	70	4,5
-FA20	22 (3/4")	63	164	70	5,0
-FA25	30 (1")	73	171	70	5,0
-FA32	39 (1 1/4")	84	177	70	5,5
-FA40	43 (1 1/2")	94	182	70	6,5
-FA50	55 (2")	109	190	70	6,5
-FA65	70 (2 1/2")	129	200	70	7,5
-FA80	82 (3")	144	207	70	8,0
-FA100	107 (4")	164	217	70	9,0
-FA125	132 (5")	194	232	70	11,0
-FA150	159 (6")	219	245	70	11,0
-FA200	207 (8")	274	273	70	15,5
-FA250	260 (10")	330	300	70	19,0
-FA300	310 (12")	385	330	70	22,0
-FA350	340 (14")	445	355	70	35,5
-FA400	390 (16")	498	385	70	41,0

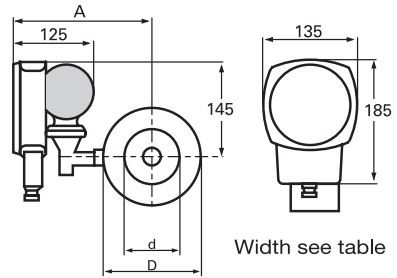

S.--GSS					
Type	D	A mm	B mm	C mm	Weight kg*
-GSS15	R 1/2"	110	130	35	3,0
-GSS20	R 3/4"	110	130	35	3,0
-GSS25	R 1"	110	130	35	3,0

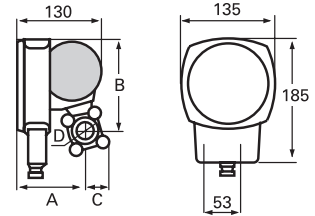

S.--FSS					
Type	d mm	D mm	A mm	Width mm	Weight kg*
-FSS15	16 (1/2")	53	179	15	3,0
-FSS20	22 (3/4")	63	185	15	3,0
-FSS25	30 (1")	73	193	15	3,5
-FSS32	39 (1 1/4")	84	200	15	3,5
-FSS40	43 (1 1/2")	94	205	15	3,5
-FSS50	55 (2")	109	220	15	4,0
-FSS65	70 (2 1/2")	129	230	15	4,0
-FSS80	82 (3")	144	238	15	4,0
-FSS100	107 (4")	164	248	15	4,5
-FSS125	132 (5")	194	263	15	5,0
-FSS150	159 (6")	219	276	15	5,5
-FSS200	207 (8")	274	303	15	7,0
-FSS250	260 (10")	330	330	15	9,0
-FSS300	310 (12")	385	355	15	10,0
-FSS350	340 (14")	445	385	18	15,0
-FSS400	390 (16")	498	415	18	17,0

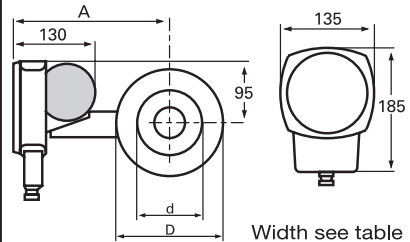

*Approximate weight

Item	Description	Nos	Item	Description	Nos
1	Screw	4	24	Microswitch	2
2	Dial glass	1	25	Spring bar	1
3	Clamp ring	1	26	O-ring	4
4	Pointer	1	27	Screw	2
5	Dial	1	28	Flow direction selector	1
6	Adjusting dial	2	29	Screw, washer, nut	4
7	Cover	1	30	Pipe body GL	1
8	Screw	2	31	O-ring (orifice)	1
9	Tool	1	32	Orifice plate GL	1
10	Casing	1	33	O-ring (spacer)	2
11	Lever/rubber seal	1	34	Spacer GL	2
12	Diaphragm housing	1	35	Threaded flange GL	2
13	Diaphragm	1	36	Connecting unit FA	1
14	Diaphragm spring	2	37	O-ring	2
15	Diaphragm cover	1	38	Shut-off valve	2
16	Screw	9	39	Screw	2
17	Fitting (Ventilation)	1	40	O-ring	2
18	Cable gland PG16/PR 22,5	1	41	Pipe body FA	1
19	Connection box	1	42	O-ring (orifice)	1
20	Terminal block	1	43	Orifice plate FA	1
21	Fitting	2	44	Spacer FA	2
22	Screw with washer	4	45	Screw and washer	4
23	Pointer mechanism	1			

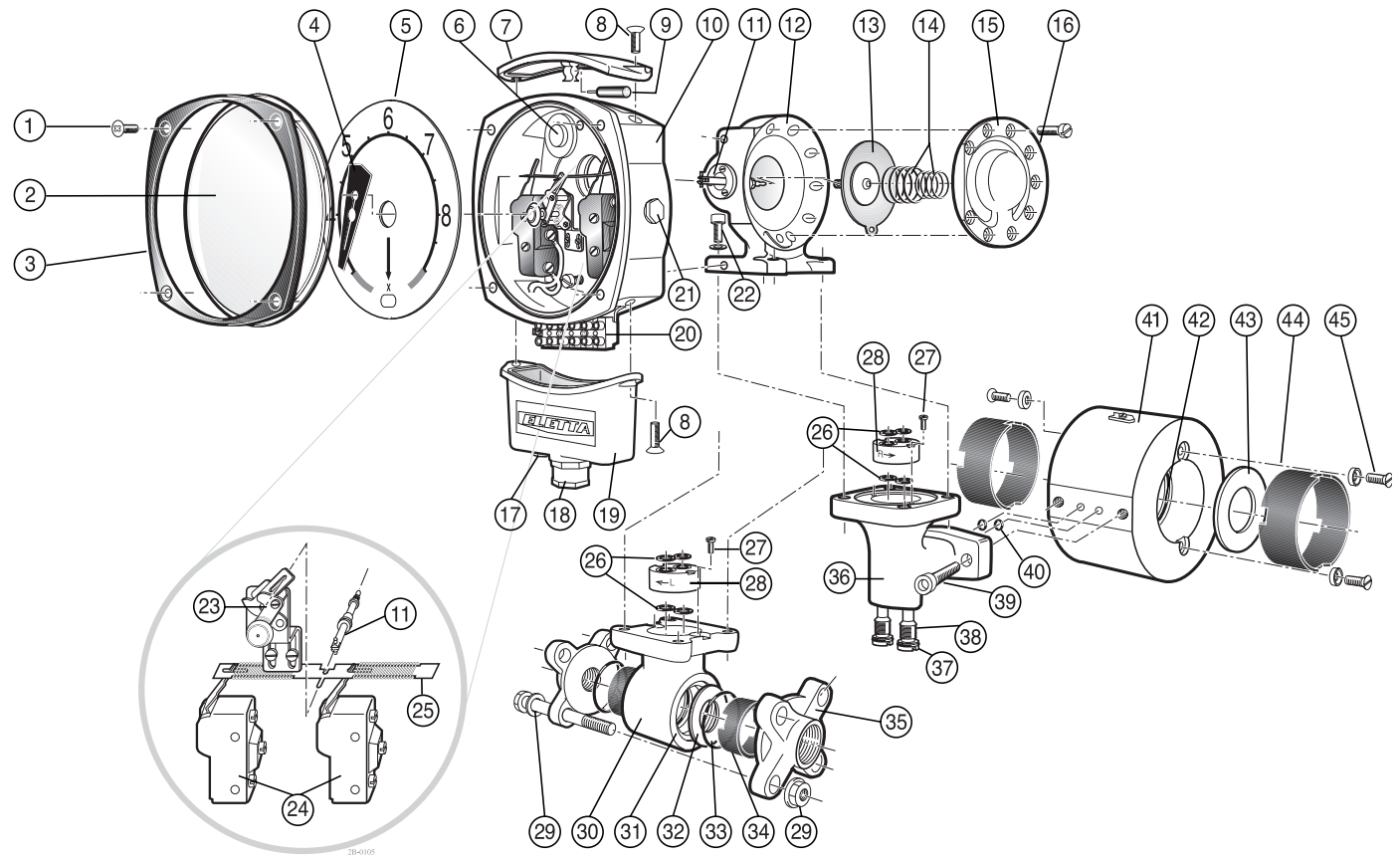

Item	Description	Nos	Item	Description	Nos
1	Screw	4	18	Cable gland (PG16/PR 22,5)	1
2	Dial glass	1	19	Connection box	1
3	Clamp ring	1	20	Terminal block	1
4	Pointer	1	21	Fitting	2
5	Dial	1	22	O-ring	2
6	Adjusting dial	2	23	Pointer mechanism	1
7	Cover	1	24	Microswitch	2
8	Screw	2	25	Spring bar	1
9	Tool	1	26	Screw	2
10	Casing	1	27	Orifice plate/Pipe unit FSS	1
11	Lever/rubber seal	1	28	Orifice plate/Pipe unit GSS	1
12	Diaphragm housing	1	29	Threaded flange, GSS	2
13	Diaphragm	1	30	Screw, washer, nut	4
14	Diaphragm spring	2	31	O-ring	2
15	Diaphragm cover	1	32	Manifold for FSS (Option)	(1)
16	Screw and washer	6	33	Shut-off valve (Option)	(2)
17	Fitting (Ventilation)	1			

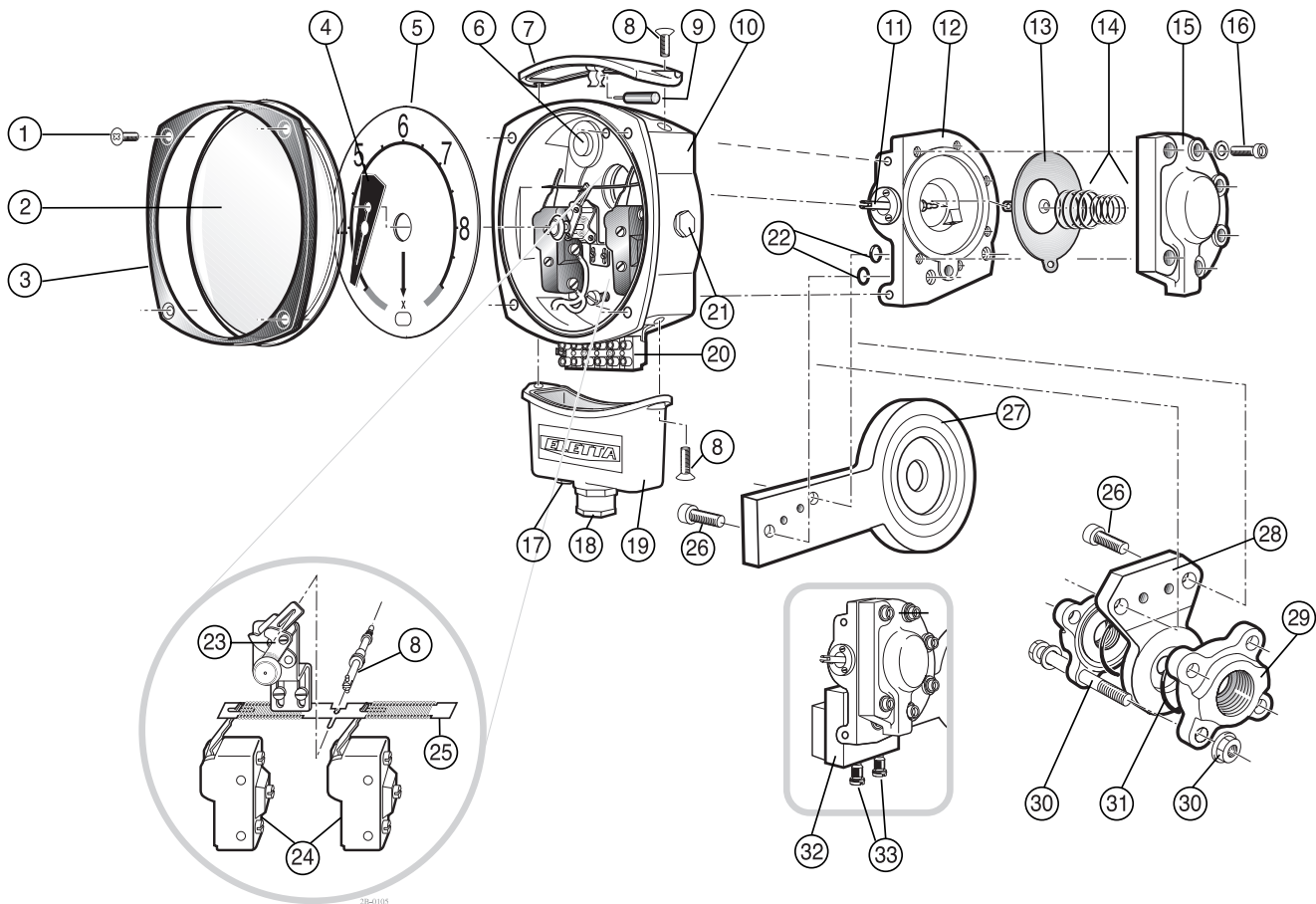



— FLOW MONITORS —