

FS-100E 2.0 - 15.0 l/min with pre-adjusted set points

FS-100E-A 1.0 - 16.0 l/min with adjustable set points

The FS-100E version (with pre-adjusted set points 2.0 . . . 6.0 l/min) operates in vertical mounting position only. It is equipped with a calibrated piston which is displaced by liquid flow to magnetically actuate a hermetically sealed reed switch isolated within the unit body. When flow decreases the piston returns to its prior position by its own weight and deactuates the reed switch. The FS-100E version (with pre-adjusted set points 5.0 . . . 15.0 l/min) operates with the same principle but a positive spring-return deactuates the switch when flow decreases. Mounting is possible in any position.

The FS-100E-A (adjustment range 1.0 . . . 16.0 l/min) operates according to the same principle as the FS-100E with spring. The FS-100E-A is provided with an additional scale on the brass body on which set points as well as setting functions can be adjusted in one operation. Only the mark of the junction box has to be moved over the respective scale value. Pressure drop is not influenced at all when changing set points.



Dimensions

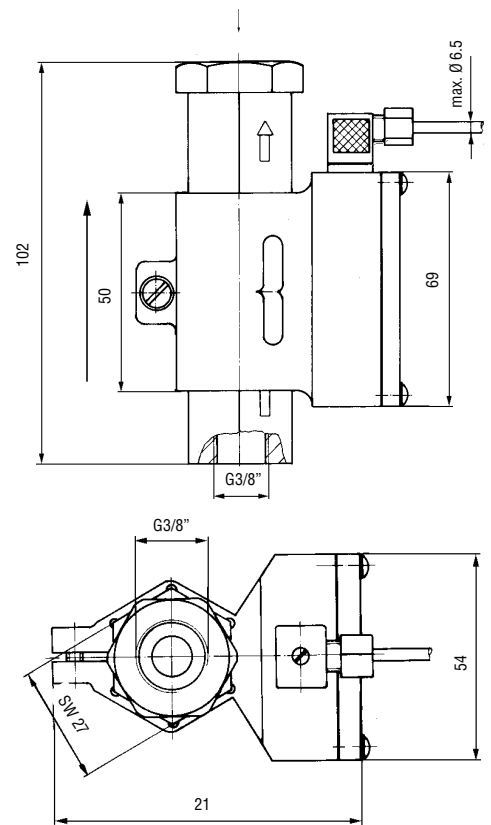

- Housing: Brass
- Piston: Brass
- O-Ring: Buna N
- Spring: Stainless Steel
- Magnet: Ferrite

Specifications (All pressure data related to water at +20 °C)

	FS-100E	FS-100E-A
Max. flow	24 . . . 40 l/min.	55 l/min
Max. operating pressure	50 bar	50 bar
Max. pressure drop	0.3 bar	0.3 bar
Max. operating temperature	+90 °C	+90 °C
Set points	see order number	adjustable 1 ... 16 l/min
Switching function (related to increasing flow)	NO/NC; the required function may be adjusted by moving the junction box	
Mounting position	see order number	any position
Factory mounting position with set point adjustment	vertical, inlet port down	vertical, inlet port down
Repeatability	± 1%	± 1%
Adjustment accuracy	±10%	±10%
Hysteresis	max. 5%	max. 20%
Mountings	G 3/8"	G 3/8"
Electrical connections	miniature plug connector with cable gland (max. cable ø: 6.5 mm)	
Enclosure	IP 65	IP65
Electrical data contact rating	40 VA, 2 A, 220 V~	
Weight	appr. 0.5 kg	appr. 0.5 kg

Order numbers

	set points (l/min)	Mounting position	order number
FS-100E	2.0	vertical	020-0402
	3.0	vertical	020-0403
	4.0	vertical	020-0404
	5.0	vertical	020-0405
	6.0	vertical	020-0406
	5.0	any position	020-0505
	6.0	any position	020-0506
	7.0	any position	020-0507
	8.0	any position	020-0508
	9.0	any position	020-0509
	10.0	any position	020-0510
	11.0	any position	020-0511
	12.0	any position	020-0512
	13.0	any position	020-0513
	14.0	any position	020-0514
15.0	any position	020-0515	
FS-100E-A		any position	020-0315

Set point adjustment/Contact configuration

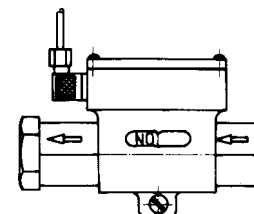

Adjust the housing to setting required

Wiring diagram

