

## Flow Switches – Liquid (continued)

### Series FS6

#### High Sensitivity Liquid Flow Switches

- For heavy duty applications where high sensitivity is required, such as water treatment systems, cooling systems for electronic circuits, compressors, booster pumps, and bearings, and other applications that need instant switching
- In-line configuration eliminates need for a pipe tee
- Very high flow capacity
- Actuates at extremely low flow rate
- Sizes available
  - 3/4" (20mm) NPT
  - 1" (25mm) NPT
- Single pole, double throw snap switch
- Switch compartment is completely sealed to protect it from the liquid
- Sensitivity adjusting screw makes flow adjustment easy
- Optional feature
  - BSPT threads
- Minimum temperature (fluid or ambient) 32°F (0°C)
- Maximum temperature 225°F (107°C)
- Maximum operating pressure 100 psi (7 kg/cm<sup>2</sup>)

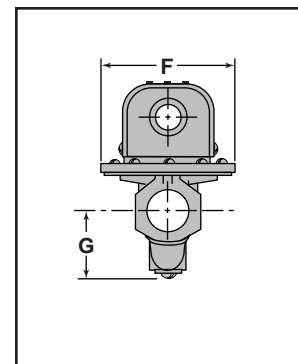
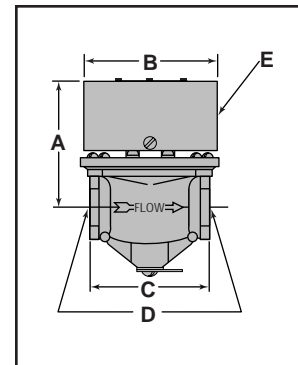

#### Dimensions, in. (mm)

A	B	C	D NPT	E	F	G
3 1/2 (89)	3 23/32 (94.4)	3 3/8 (86)	3/4 or 1 (20 or 25)	7/8 (22)	3 3/4 (95)	2 (51)

### Model FS6-W

#### High Sensitivity Liquid Flow Switches

- For applications requiring a water-tight, dust-tight, or a NEMA 4X rated flow switch

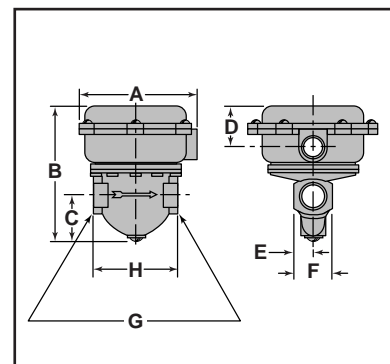

#### Dimensions, in. (mm)

A	B	C	D	E	F	G NPT	H
5 (127)	5 3/4 (146)	2 (51)	1 5/8 (41)	2 9/32 (23)	1 13/16 (46)	3/4 or 1 (20 or 25)	3 3/8 (86)

FLOW SWITCHES

### Electrical Ratings

Voltage	Motor Switch Rating (Amperes)		Pilot Duty
	Full Load	Locked Rotor	
120 VAC	7.4	44.4	125 VA at 120 or 240 VAC 50 or 60 cycles
240 VAC	3.7	22.2	

### Flow Rates

Pipe Size NPT in. (mm)	Settings	Mode of Operation		Max. Flow Rate (GPM) w/o Paddle Damage
		Flow gpm (lpm)	No Flow gpm (lpm)	
3/4 (20) or 1 (25)	Factory or			
	Minimum	.12 (.45)	.06 (.23)	16.62
	Maximum	2.5 (9.46)	1.5 (5.68)	27

Values are ± 10%

### Ordering Information

Model Number	Part Number	Description	Weight lbs. (kg)
FS6-3/4	115400	Very high sensitivity flow switch w/3/4" (20mm) NPT	4.5 (2)
FS6-1	115600	Very high sensitivity flow switch w/1" (25mm) NPT	4.5 (2)
FS6-J-3/4	115550	FS6-3/4 w/BSPT threads	4.5 (2)
FS6-J-1	115650	FS6-1 w/BSPT threads	4.5 (2)
FS6-W-3/4	115651	FS6-3/4 NEMA 4X rated	4.5 (2)
FS6-W-1	115652	FS6-1 NEMA 4X rated	4.5 (2)
FS6-WJ-3/4	115653	FS6-W-3/4 w/BSPT threads	4.5 (2)
FS6-WJ-1	115654	FS6-W-1 w/BSPT threads	4.5 (2)

**NOTE: DO NOT USE LIQUID FLOW SWITCHES ON SYSTEMS WITH FLOW GREATER THAN 10 FEET (3M) PER SECOND.**