

Low Water Cut-Offs

Combination Low Water Cut-Off/Pump Controllers for Steam Boilers (cont.)

Series 93   
Low Water Cut-Off/Pump Controllers

- For commercial and industrial low or high pressure steam boilers
- Maintains consistent water level regardless of pressure
- For boilers of any steaming capacity
- No. 5 Switch included
- Magnetic repulsion eliminates need for bellows
- Optional features
 - Manual reset
 - On/Off or proportional control switch to maintain constant boiler water level
 - BSPT threads
- 1" (25mm) NPT connections
- Maximum pressure 150 psi (10.5 kg/cm²)

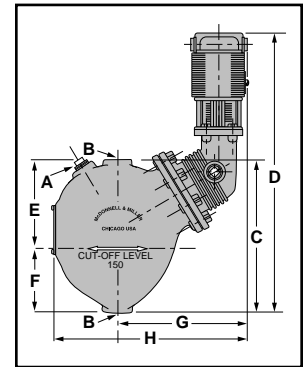

Electrical Ratings

345 VA at 120 or 240 VAC

Dimensions, in. (mm)

A	B	C	D	E	F	G	H
NPT	NPT						
¾ (20)	1 (25)	10 ¹ / ₁₆ (256)	18 ⁵ / ₈ (473)	4 ¹⁵ / ₃₂ (113.5)	5 ¹⁹ / ₃₂ (142)	8 ⁷ / ₈ (225)	12 ⁷ / ₈ (327)

Ordering Information

Model Number	Part Number	Description	Weight lbs. (kg)
93	162300	Combination low water cut-off/pump controller w/No. 5 switch	35.0 (15.9)
93-J	162325	93 w/BSPT threads	35.0 (15.9)
93-J-7B	162330	93 w/BSPT threads & No. 7-B switch	35.5 (16.0)
93-M	162500	93 w/manual reset	35.0 (15.9)
93-MJ	162525	93-M w/BSPT threads	35.0 (15.9)
93-7B	163000	93 w/No. 7B switch	35.5 (16.0)
93-7B-M	163100	93-7B W/manual reset	35.5 (16.0)