

Float chambers

Wherever it is not possible or desirable to install float switches directly onto a vessel, horizontal TriMod BESTA level switches can be mounted externally in a float chamber. This type of installation allows functional checks and servicing to be carried out without interrupting operation, provided that isolation and drain valves are included in the process connections.

Float chambers may be divided into 3 groups.

- Chambers in gray cast iron, PN 16 acc. to DIN. For mounting level switches of the Standard Range (square flange).
- Standard chambers, PN 25 acc. to DIN in various steel qualities and types. For mounting level switches of the Standard Range.
- Industrial chambers, up to PN 315 acc. to DIN or class 2500 acc. to ANSI, in various steel qualities and types. For mounting level switches of the Industrial Range.

The wide choice of chamber types possible cannot be covered in this catalogue. For detailed information please refer to our float chamber data sheets and the BESTA float chamber manufacturer specification.

All float chambers are hydraulically tested at 1.3 or 1.5 times the maximum operating pressure, according to specifications.

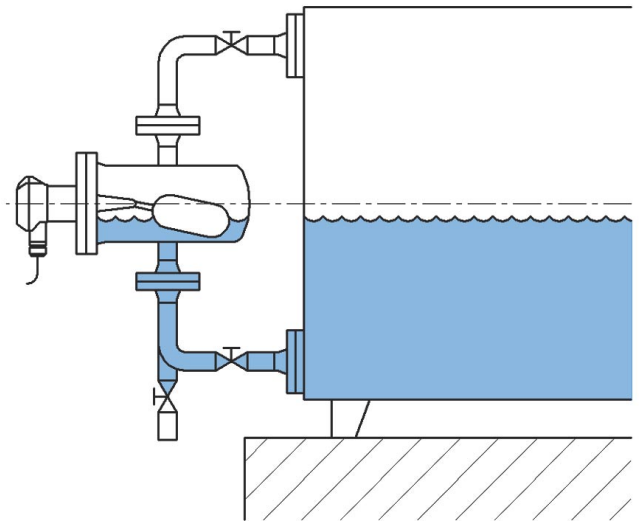

Table 36

Cast iron chambers

Type	Specification	PN	Temperature range in °C	Material	Dimensions/ process connection
SG10	Cast iron chamber for Standard Range level switches, incl. studs and nuts (M 12) on process and switch flange connections	16	-10 to +300	GG 20	
SG20	Cast iron chamber as above, with extended studs on the switch flange connection for mounting a test actuator	16	-10 to +300	GG 20	

Raised face flange facing type C in accordance with DIN 2526 for process connections.

Table 37

Standard chambers PN 25

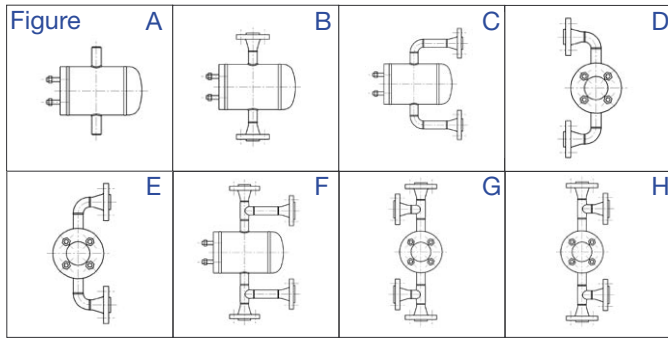

Types According to figures A to H
 Process connections DN 25, 50 in accordance with DIN
 DN 1", 2" in accordance with ANSI
 Material Carbon steel
 High temperature steel
 CrNi steel
 CrNiMo steel

Flange facing of process connections in accordance with DIN 2526
 in accordance with ANSI B 16.5

Options Special dimensions
 Vent and drain connection
 Long studs for mounting a test actuator
 Float chambers for low temperature applications
 Float chambers with max. hardness of HRC 22 in accordance with NACE

Table 38

Industrial chambers PN 40 to 100 and ANSI cl. 150 to 600

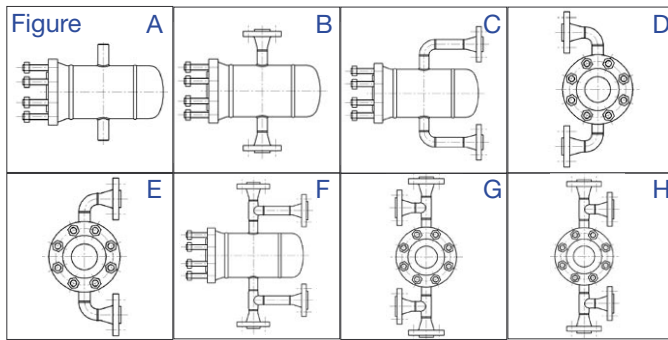

Types According to figures A to H
 Process connections DN 25, 50 in accordance with DIN
 DN 1", 2" in accordance with ANSI
 Material Carbon steel
 High temperature steel
 CrNi steel
 CrNiMo steel

Flange facing of process connections in accordance with DIN 2526
 in accordance with ANSI B 16.5

Options Special dimensions
 Vent and drain connection
 Chambers up to PN 315 in accordance with DIN
 cl. 2500 in accordance with ANSI
 Float chambers for low temperature applications
 Float chambers with max. hardness of HRC 22 in accordance with NACE

Procedure Qualification Record:

- SVTI 505 (EN 288)
- AD HP 2/1
- ASME Code Sec. IX

Approved welders in accordance with:

- SVTI 504 (EN 287)
- AD HP 3
- ASME Code Sec. IX

Type approval:

SAQ Kontroll AB
 ÅF Kontroll AB

Approval for material transfer stamping in accordance with
 - SVTI 201/507

For float chambers in Tables 37 and 38, the following options, tests and documentation are available:

Test report in accordance with EN 10204-2.2

Inspection certificate in accordance with EN 10204-3.1B

Non destructive testing such as ultrasonic, X-ray, dye penetrant or magnetic particle examination

Material testing including charpy, tensile and hardness

Coatings